



P i l o T R E K

NON-CONTACT RADAR LEVEL TRANSMITTER



- ◆ Non-contact level transmitter for liquids and solids
- ◆ Not influenced by dielectric constant, temperature, pressure and density variations
- ◆ Accuracy up to ± 1 mm
- ◆ Measuring range up to 100 m
- ◆ Tank bottom following (TBF) mode for media with low dielectric constant
- ◆ Flange temperature up to 250 °C
- ◆ Medium temperature -60 °C ... $+600$ °C
- ◆ Pressure up to 64 bar
- ◆ HART, Profibus PA, FF, RS485
- ◆ ATEX explosion-proof approval

ABOUT PILOTREK

PiloTREK being an FMCW (frequency modulated continuous wave) type radar level gauge offers the highest standard of non-contact level metering technology for liquids and solids without any compromise in the performance with an accuracy also suitable for Custody transfer measurement.

The four models range from the 2-wire low cost to the 4-wire high precision version. Their horn antenna or Wave-Stick come with a wide variety of materials, while the most different sealings provide the chance of the proper choice for any application.

The FMCW radar uses high frequency wave of 8,5 GHz with a 1 GHz frequency sweep for the measurement. A wave is emitted by the antenna and received with a time delay depending on the distance of the measured surface. The lower frequency of the emitted wave is compared with the frequency generated at the time the reflected wave reaches the antenna. The frequency difference Δf is a basic variable for distance calculation. The mix signal of two frequencies is transformed via a Fast Fourier Transformation (FFT) into a frequency spectrum from which distance and level is calculated.

The unique TBF and partial TBF method provides for reliable measurement even with very low relative dielectric constants between 1,05 and 4 when the waves reflected from the surface of the medium are very weak. TBF (tank bottom following) method uses the electromagnetic waves going through the medium.

In this case the level is calculated from the virtual moving away of the bottom caused by the „impeding“ effect of the waves in the material. Partial TBF represents the possibility to activate the TBF only below a certain filling level above which the direct measurement is applied automatically.

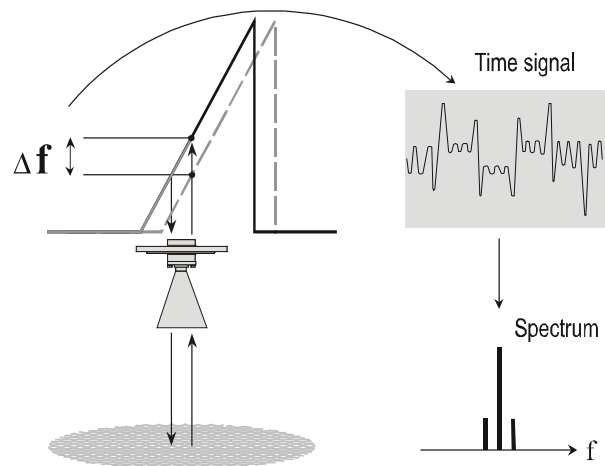

TECHNICAL DATA

TYPE		PILOTREK 2-WIRE
Special features		Empty tank spectrum recording, Partial or Full TBF mode, Low cost L flange system
Range		max. 20 m
Min. top block distance	Horn	For storage tanks: antenna extension + antenna length + 100 mm, for process tanks: additional +100 mm
	Wave-Stick	Wave-Stick length – 200 mm
	Still-Well	Antenna extension + antenna length + 300 mm
Error of measurement		Range <5 m: ±10 mm Range >5 m: ±10 mm ±0.2%
Analogue output		4 ... 20 mA passive
Communication		HART (standard)
Power supply		Non Ex: 17 ... 35 V DC; For Ex i application: intrinsically safe power supply is required
Flange temperature (with heating device or temperature adapter)		Horn: -30°C (-60°C) ... +130°C (+250°C); PP Stick: -20°C ... +100°C; PTFE Stick: -40°C ... +130°C (+150°C); with L flange system: -20°C ... +130°C
Ambient temperature		-20 °C ... +55 °C
Process pressure		Horn: max. 40 bar; Wave-Stick with plate: -1...16 bar, Wave-Stick without plate and L flange: max. 2 bar
Relative dielectric constant		$\epsilon_r \geq 1,5$ (with Wave-Stick: $\epsilon_r \geq 4$) for media with $\epsilon_r < 3$ Still-Well or Wave-Guide or TBF mode is recommended
Conduit (quantity, pc.)		M 20 x 1.5 standard (1); Quickon (1), ½" NPT (1), BSP ½" (1) on request
Antenna types and materials		Horn: 1.4571 (316Ti), Hastelloy, Titanium, Tantalum, Wave-Stick with plate: PTFE; Wave-Stick without plate: PP +FPM sealing or PTFE + FFKM sealing SW short Wave-Stick: PTFE with plate for Still-Well only, Still-Well (on request) of stainless-steel.
Max. tracing velocity		10 m / min
Weight		6 kg (with DN 50 PN40 flange)
Wetted parts		1.4571 (316 Ti), Hastelloy C4 or B2, Titanium, Tantalum, PP, PTFE
Gaskets		FPM, FFKM 4079, 2035, 6375, 1091
Ex approvals		⊕ II 1/2 G EEx ia IIC T6
Ingress protection		IP 66 / 67

TYPE		PILOTREK 4-WIRE LOW COST	PILOTREK 4-WIRE HIGH PERFORMANCE	PILOTREK 4-WIRE HIGH PRECISION
Special features		Empty tank spectrum recording, Partial TBF mode, Low cost L flange system	Empty tank spectrum recording For solids and for difficult applications, Partial or full TBF mode, Digital input + Switching output,	High accuracy, Empty tank spectrum recording, Partial TBF mode, Digital input + Switching output
Range		0.5 ... 20 m	0.5 ... 40 (100) m (with Wave-Stick: max. 20 m)	0.5 m... 35 m (with Still-Well: max. 30 m)
Min. top block distance	horn	for storage tanks: antenna extension + antenna length + 100 mm, for process tanks: antenna extension + antenna length + 200 mm		
	stick	stick length – 200 mm		
	Still-Well	antenna extension + antenna length + 300 mm		
Error of measurement		Horn antenna: ±10 mm <2 m range<: ±0.3% Wave-Stick: ±15 mm <2 m range<: ±0.3%	Horn antenna: ±10 mm <2 m range<: ±0.3% special calibration: ± 5 mm <5 m range <: ±0.1% Wave-Stick: ±15 mm <2 m range<: ±0.3%	±1 mm <10 m range<: ±0.01%
Analogue output		4 ... 20 mA active	4 ... 20 mA active (standard) or 4 ... 20 mA passive (on request)	
Communication		HART (standard)	HART (standard); Profibus PA, Fieldbus Foundation, RS 485 Smart protocol (on request)	
Power supply		19.2 ... 28.8 V DC / 20.4 ... 26.4 V AC	200 ... 240 V AC or 100 ... 120 V AC or 18 ... 31.2 V DC/ 18 ... 26.4 V AC	
Flange temperature (with heating or temp. adapter)		Horn: -30 °C (-60 °C) ... +130 °C (+250 °C) Wave-Stick: -40 °C ... +130 °C (+150 °C) with L flange system: -20 °C ... +130 °C	Horn: -30 °C (-60 °C) ... +130 (250 °C) Wave-Stick: -40 °C ... +130 (150 °C) with L flange system: -20 °C ... +130 °C	Horn: -30 °C (-60 °C)...+130 °C (250 °C) Note: L flange system is not available
Ambient temperature		-20 °C ... +55 °C	-20 °C ... +55 °C (-40 °C...+70 °C for maximum 2 hours)	-20 °C ... +55 °C
Process pressure		Horn antenna: -1 ... 64 bar Wave-Stick with plate: -1...16 bar (p=43-0,3T) Wave-Stick without plate and L flange system: max. 2 bar	Horn antenna: -1 ... 64 bar Note: L flange system is not available	
Minimum relative dielectric constant		$\epsilon_r \geq 1,5$ (with Wave-Stick: $\epsilon_r \geq 4$) for 1,5 < ϵ_r ≤ 3 Still-Well or Wave-Guide or TBF mode is recommended		$\epsilon_r \geq 1,5$ Still-Well or Wave-Guide is recommended
Conduit (quantity, pc.)		M 25 x 1.5 (2) standard; M 25 x 1.5 for -40 °C (2), ½" NPT (2)	M 25 x 1.5 (2) standard; M 25 x 1.5 for -40 °C (2), ½" NPT (3), ½" BSP (3)	
Antenna types and materials		Horn: 1.4571 (316Ti), Hastelloy, Ti, Ta, Wave-Stick with plate: PTFE (made of PTFE monoblock) Wave-Stick without plate: PP + FPM sealing or PTFE + FFKM sealing SW short Wave-Stick: PTFE with plate for Still-Well only (Still-Well of stainless-steel on request), Wave-Guide antenna: 1.4571		Horn: 1.4571 (316Ti), Hastelloy, Ti, Ta, Wave-Guide antenna: 1.4571 Still-Well (on request): stainless-steel
Max. tracing velocity		10 m / min		1 m / min
Weight		10 ... 30 kg	12 ... 32 kg	
Wetted parts		1.4571 (316 Ti), Hastelloy C4, Ti, Ta, PP, PTFE		1.4571 (316 Ti), Hastelloy C4, Ti, Ta
Gaskets		FPM (standard), FFKM 6375, 4079, 2035, Parofluor, FEP coated FPM		
Ex approvals		⊕ II 1/2G EEx de IIC T6...T1; ⊕ II 2G EEx de IIC T6...T1	⊕ II 1/2G EEx de IIC T6...T1; ⊕ II 2G EEx de IIC T6...T1; ⊕ II 1/2G EEx de [ia] IIC T6...T1; ⊕ II (1)2 G EEx de [ia] IIC T6...T1	
Ingress protection		IP 66 / 67		

DIMENSIONS

Dimensions in mm

2-WIRE UNIT

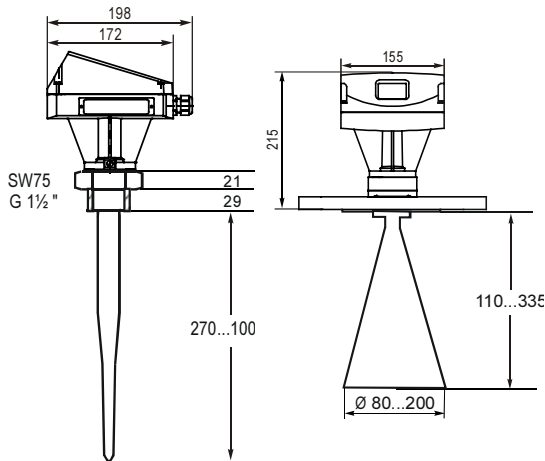

4-WIRE LOW COST UNIT

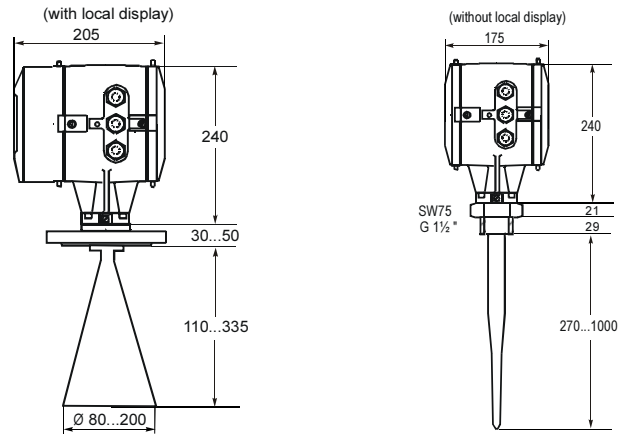

4-WIRE HIGH PERFORMANCE AND HIGH PRECISION UNIT

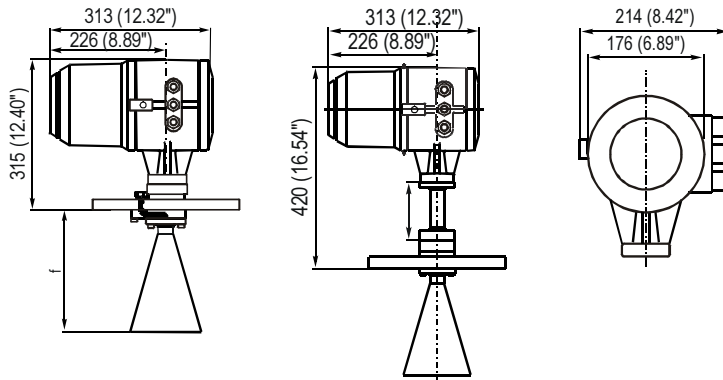

SUNSHADE

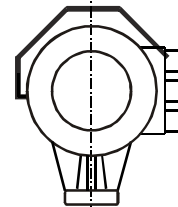

Recommended as protection for the signal converter against direct sunshine. Increases overall height by approx. 20 mm (0.79").

ANTENNA TYPE	MATERIAL	ANTENNA DIAMETER	ANTENNA LENGTH	MAX. EXTENSION OF THE CONNECTING NOZZLE**	TRANSMISSION ANGLE	LOBE EXPANSION PER 1 M DISTANCE
		D	L	X	α	s
Horn	1.4571, Hastelloy	80 mm / 3" *	110 mm	-	16° *	300 mm / 12"
		100 mm / 4" *	150 mm	-	12° *	220 mm / 9"
		140 mm / 5.5"	220 mm	215 mm	8°	140 mm / 5.5"
		200 mm / 8"	340 mm	335 mm	6°	100 mm / 4"
Wave-Stick	PP, PTFE	25 mm / 1"	270 mm / 10.6"	50 mm	9°	160 mm / 6.3"
			384 mm / 15.1"	150 mm		
			500-1000 mm / 20-40"	L-234		
Wave-Guide	1.4571, Hastelloy	DN 25 mm / 1"	600-3000 mm for Ex 600-6000 mm for non Ex	-	Propagation only inside the wave-guide	
Still-Well	Stainless-steel	DN 50-200 mm / 2-8"	> 600 mm	-	Propagation only inside the Still-Well	

* Should only be used in conjunction with Still-Well. The transmission angle given applies to line-of-sight propagation, i.e. without Still-Well.

** Antenna extensions are available from 100 to 2000 mm (4" to ~80") in steps of 100 mm (~4"). Several extensions can be joined up.

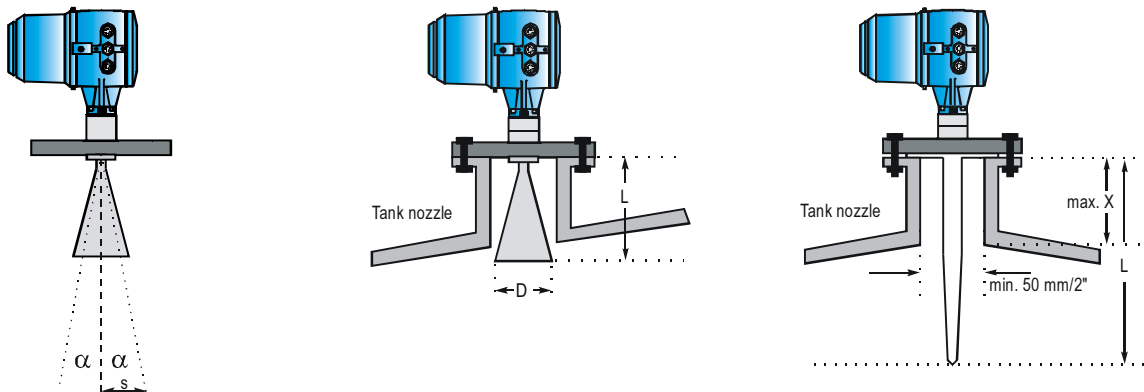

APPLICATION

Modular system of PiloTREK offers easy selection of moduls for ideal configuration.

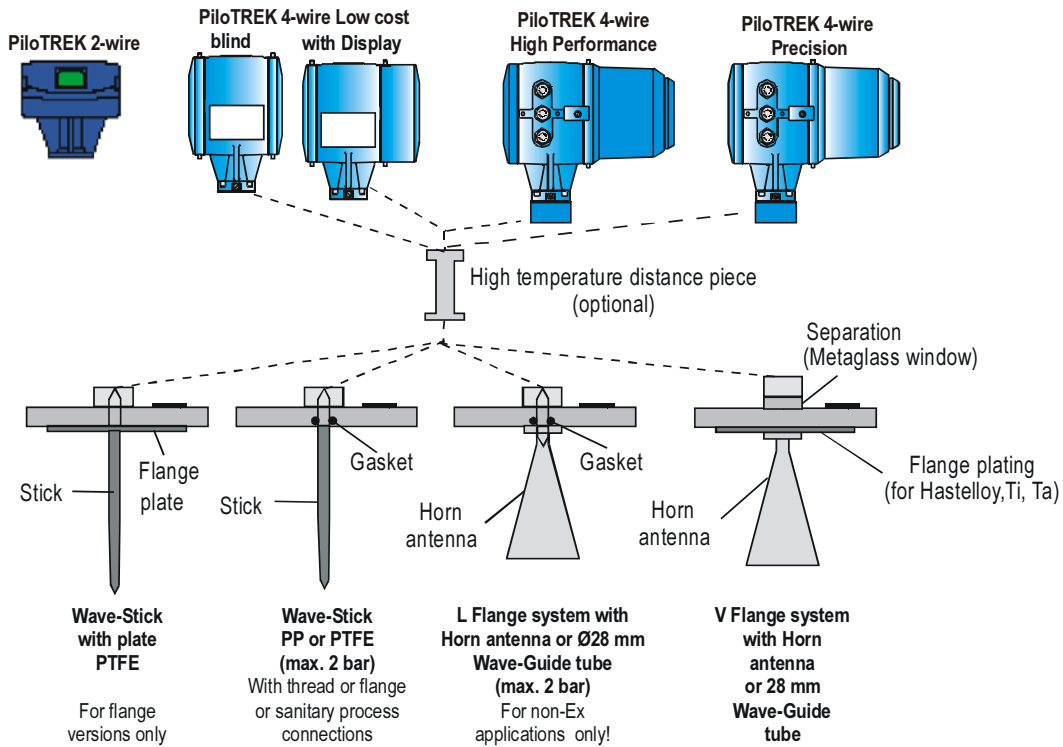

Looking at the Technical data, special features of the units provide guidance to the best choice. There is a recommendation below based on application experience for the optimum application range, in order to minimize potential problems. If the recommended antenna cannot be accepted, any other configuration may also be tested.

Antennas $d = 80$ and 100 mm should only be used with Still-Wells.

For PiloTREK 4-wire high precision always $d = 200$ mm horn antenna is suggested. If the application requires the use of Still-Well, it should be of $DN \geq 100$ mm / 4".

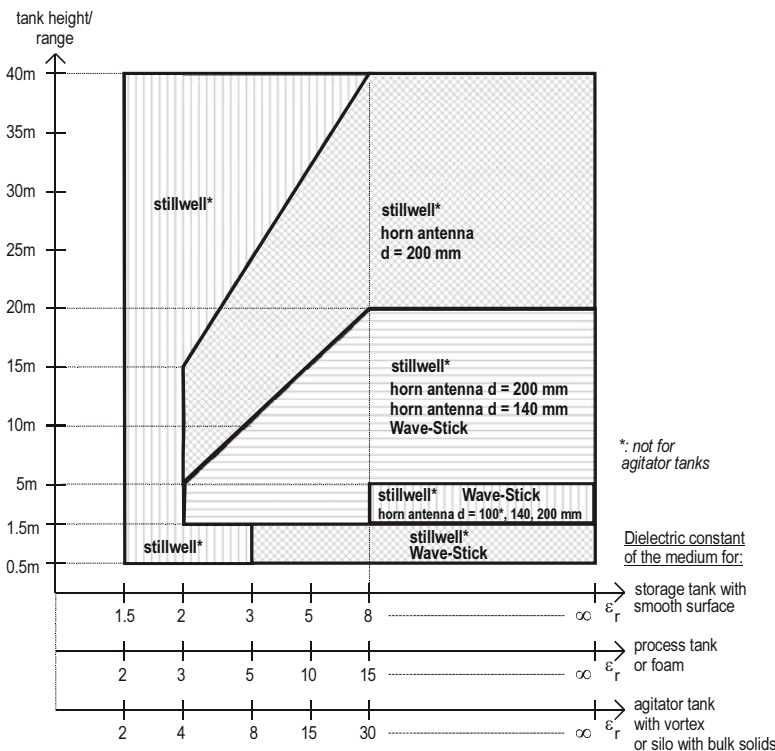

WIRING

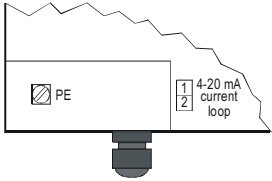
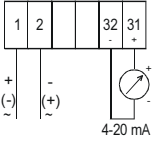
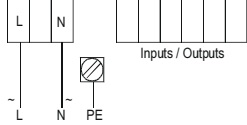
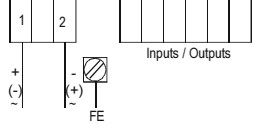
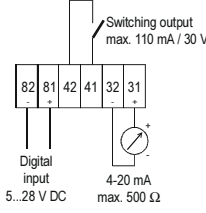
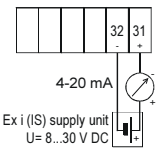
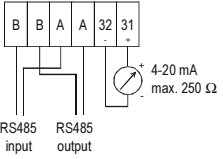
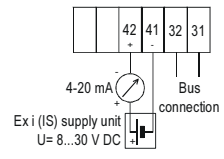
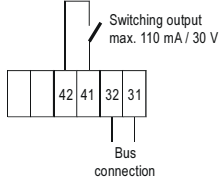
PiloTREK 2-wire Low Cost		PiloTREK 4-wire Low Cost	
<p>Power supply: 17...35 V DC max. 22 mA</p> <p>The polarity of the 4-20 mA connection is arbitrary.</p> <p>Output: Passive 4-20 mA with HART</p>		<p>Power supply: 24 V DC \pm20% 24 V AC +10/-15%</p> <p>Current consumption: <300 mA</p> <p>Output: Active 4-20 mA with HART Load: max.350 Ω</p>	
PiloTREK 4-wire High Performance and PiloTREK 4-wire High Precision			
Power Supply connections			
 <p>High voltage connection for 100...120 V AC or 200...240 V AC</p>		 <p>Low voltage connection for 18...31,2 V DC / 18...26,4 V AC Connection of a FE functional ground is not mandatory.</p>	
Output / Input connections			
 <p>* standard electronics version, all others on request Active current output with HART, Ex e Digital input for freeze or warmstart and Switching output *</p>		 <p>Passive current output with HART, Ex i</p>	
 <p>RS485 and Active current output</p>		 <p>Profibus PA or FF and Passive current output</p>	
 <p>Profibus PA or FF with Switching output</p>			

INSTALLATION

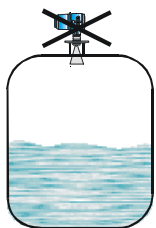

Do not position in tank just to the centreline!!!
(multiple reflections!)

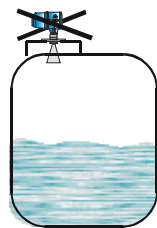

Do not mount just to centre on manhole cover!
(multiple reflections!)



A standard Wave-Stick not functions in a Still-Well!

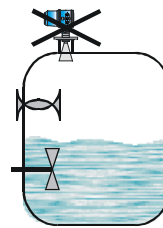

Do not position above internals!
(interference reflections!)

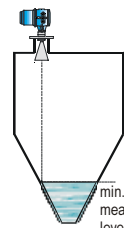

Lower measuring range limited when tank has tapered bottom.

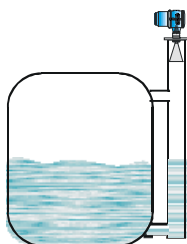

Horn antenna in a side vessel

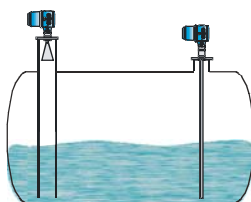

Use Still-Well (on request) or Wave Guide pipe in horizontal cylindrical vessel

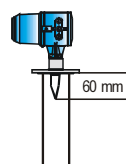

Stick SW type antenna for Stilling Wells DN=40-55 mm (on request)

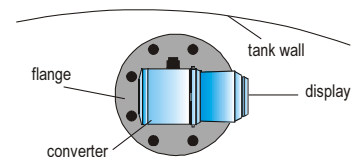

Mount the flange the axis of the (direction display) is oriented tangentially to the tank wall (the radar signal is polarised)

ACCESSORIES

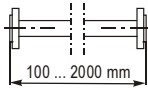

Straight antenna extension AAE - 1□□

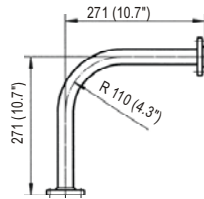

L-shape antenna extension AAL - 101

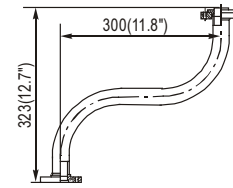

S-shape antenna extension AAS - 101

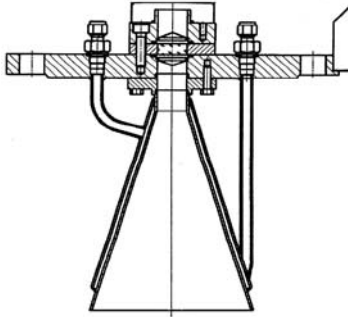

Antenna heating/cooling device, for flanges ≥ DN150 (6")

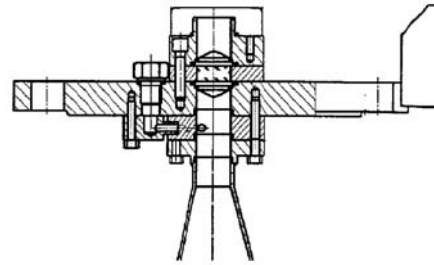

Antenna purging device, for flanges ≥ DN100 (4")

ORDER CODES (NOT ALL COMBINATIONS ARE POSSIBLE)

PiloTREK A □ □ - □ □ - □ □

TRANSMITTERS	CODE	ANTENNA TYPE	CODE	PROCESS CONNECTION	CODE	ANTENNA SIZE/TYPE	CODE	HORN, WAVE-GUIDE/SEALING	CODE	POWER SUPPLY	CODE
2 wire		Stick, SW / EU	A	1½" BSP	H	D = 80 mm/Horn ¹	1	1.4571 / FPM ⁷	1	230 V AC	1
Transmitter	K	Stick, SW /USA	B	1½" NPT	J	D = 100 mm/Horn ¹	2	1.4571 / FFKM 2035	2	110 V AC	2
Transmitter + display	L	Stick / EU / L	C	DN 50 PN 40	1	D = 140 mm/Horn ²	3	1.4571 / FFKM 4079	3	24 V DC ⁶	3
Transmitter + HT	M	Stick / USA / L	D	DN 80 PN 16	2	D = 200 mm/Horn	4	1.4571 / FFKM 6375	4	24 V AC/DC	4
Transmitter + displ. + HT	N	Horn	F	DN 100 PN 16	3	D = 300 mm/Horn	5	HC4 / FPM	5	Ex VERSIONS	
4 wire low cost		Horn / L	G	DN 150 PN 16	5	L = 384 mm/Stick ^{3,5}	6	HC4 / FFKM 2035	6	230 V AC / EEx de	5
Transmitter	P	Wave-Guide pipe	H	DN 200 PN 10	6	L = 5 00 mm/Stick ^{4,5}	7	HC4 / FFKM 4079	7	110 V AC / EEx de	6
Transmitter + display	R	Special version	X	DN 250 PN 10	O	L = 600 mm/Stick ⁵	8	HC4 / FFKM 6375	8	24 V DC / EEx 1G (Zone0) ⁶	7
Transmitter + HT	S			2" ANSI 150 lb	A	L = 800 mm/Stick ⁵	9	Special version	X	24 V AC/DC / EEx de	8
Transmitter + displ. + HT	T			3" ANSI 150 lb	B	L = 60 mm/SW ¹	A			230 V AC / EEx d	A
4 wire High Performance				4" ANSI 150 lb	C	Special version	X			110 V AC / EEx d	B
Transmitter	O			6" ANSI 150 lb	D					24 V DC/EEx 2G (Zone1) ⁶	C
Transmitter + display	Y			8" ANSI 150 lb	T					24 V AC/DC / EEx d	D
Transmitter + HT	H			50 A JIS 10 K	P					Special version	X
Transmitter+displ. + HT	J			80 A JIS 10 K	I						
4 wire Precision				100 A JIS 10 K	V						
Transmitter	U			150 A JIS 10 K	W						
Transmitter + display	V			200 A JIS 10 K	F						
Transmitter + HT	Z			DN 50 Milch	L						
Transm. + display + HT	W			DN 65 Milch	G						
				DN 80 Milch	E						
Special version	X			2" Tri Clamp	N						
				3" Tri Clamp	K						
				Special version	X						

WAVE G. LENGTH FOR A□H - □ TYPE	CODE
< 1.0 m	A
< 1.5 m	B
< 2.0 m	C
< 2.5 m	D
< 3.0 m	E
< 3.5 m	F
< 4.0 m	G
< 4.5 m	H
< 5.0 m	J
< 5.5 m	K
< 6.0 m	L

STICK / SEALING MATERIAL	CODE
PTFE / PTFE plate	A
PTFE without plate/ KFKM 6375	B
PP w-o plate / FPM	C

ACCESSORIES

- AAE-101-0M** straight antenna extension 100 mm
: in 100 mm steps
- AAE-120-0M** antenna extension 2000 mm
- AAS-101-0M** "S" type 323/300 mm antenna extension
- AAL-101-0M** 90° "L" type 271/271 mm antenna extension

- NOTICE**
- 1 Only for Still-Well (measuring pipe)
 - 2 D = 145 mm for special enamelled horn type
 - 3 L = 270 mm for L flange system
 - 4 L = 400 mm for L flange system
 - 5 EEx 1 G (Zone 0) not possible
 - 6 Only for 2-wire instrument
 - 7 In case of L flange sealing is of FFKM 6375